



MARINE DIESEL ENGINES



FNM HPE 110

Configuration	4-stroke diesel, DOHC 16 V with timing chain
Maximum output at crankshaft	80,8 kW/ 110 hp at 4000 rpm
Maximum torque	216 Nm at 2200 rpm
Displacement	1248 c.c.
Bore x stroke	69.6 x 82 mm
Cylinders	4, in line
Injection system	Direct Injection Common rail
Aspiration	Supercharged with turbo
Starting system	Electric starting 12 V - 1.3 kW
Alternator	14 V - 75 A
Cooling system	Double water cooling system with heat exchanger
Lubrication system	Forced lubricating system with pump
Max mounting inclination	10°
Dry weight without transmission	160 kg
Environmental	Meets the EU comprehensive emissions regulation 2006
Engine mounting	Rubber type anti-vibration mounting

Performance Curves (Output is according to ISO 8665)

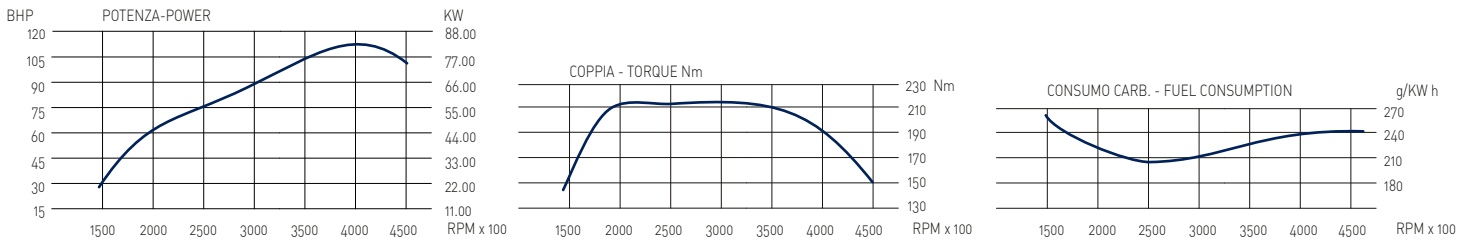

Dimensions (For detailed line-drawings, please refer to our website www.fnm-marine.com)

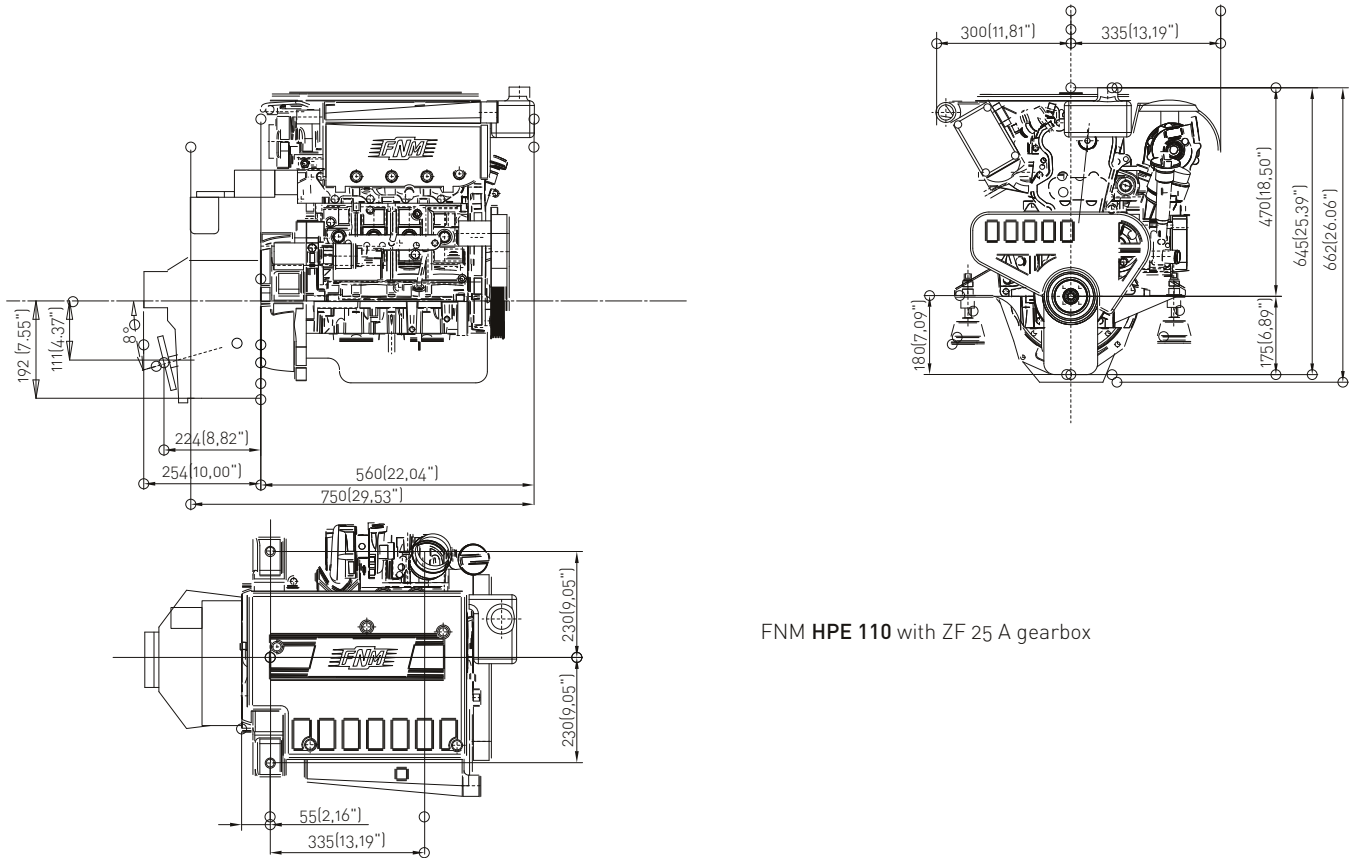

FNM HPE 110 with ZF 25 A gearbox

Panel instrument:

- Oil pressure
- Water temperature
- Voltmeter
- Rpm
- 8 meter cable

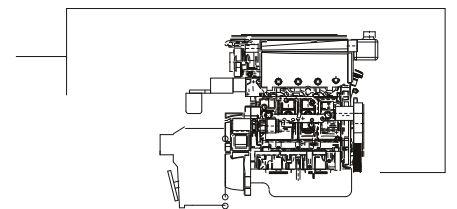

Accessories:

Standard Package

- Hydraulic gearbox
- Set of flexible mounts
- Alternator 14 V - 75 A
- Starter motor 12 V - 1,3 kW
- Fuel and oil filter

- Seawater-cooled exhaust elbow
- Racor filters
- Panel instrument with 8 mt. cable
- Seawater pump in bronze
- Engine top cover
- Water-cooled exhaust manifold

Optional

- Kit for boat internal heating
- 8 mt. auxiliary extension cable

- Flybridge instrument panel with 8 mt. cable
- Trolling valve
- 2-groove front pulley

Text and illustrations are not binding. CMD, owner of the FNM brand, reserves the right to introduce adaptations without prior notification. Vers. Eng. 15/10/08
Compliant with the RCD 2003/44/CE emission standards

